

## Spraywater Control Valve type ESV

200 MW / 300 MW / 600 MW / 750 MW / 1000 MW

- High-pressure valve
- DN 15 - 200
- PN 10 - 400 / ANSI Class 150 - 2500
- Flow to close plug
- Perforated plug
- Parabolic plug
- Low actuating force
- Low maintenance efforts

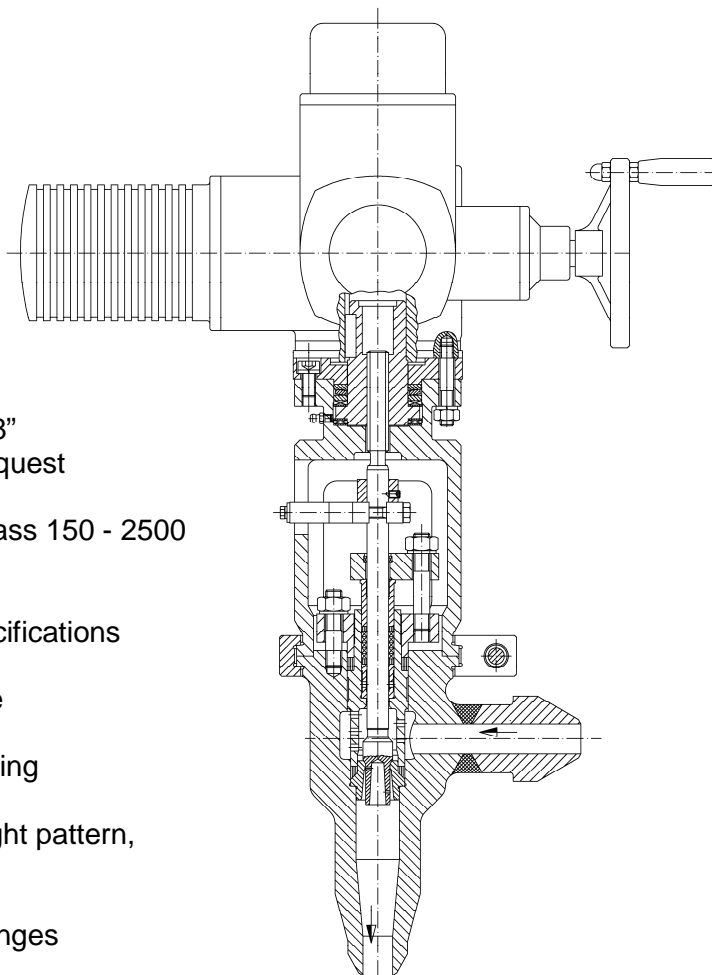

Nominal Size:	15 / 1/2" – 200 / 8" other sizes on request
Rating:	PN 10 – 400 / Class 150 - 2500
Control Range:	1:25, 1:30, 1:50 according to specifications
Control characteristic:	equal percentage
Design:	forged steel-welding construction, angle form, straight pattern, z-type
Connections:	welding ends, flanges
Actuators:	hydraulic, pneumatic, electric, according to specifications

All materials according to DIN or ANSI / ASTM. For the main parts of our valves we use standard material as listed below or according to our customer specifications.

Material acc. to DIN	Description acc. to DIN	Material ASTM/AISI/ASME
1.0460	C22.8	ASTM A105
1.4541	X6CrNiTi18-10	SUS 321
1.4571	X6CrNiMoTi17-12-2	SUS 316Ti
1.4903	X10CrMoVNb9-1	ASTM A182 F91
1.4922	X20CrMoV12-1	
1.5415	16Mo3	ASTM A182 F1
1.7335	13CrMo4-5	ASTM A182 F12
1.7380	10CrMo9-10	ASTM A182 F22